

Spare parts list
Liste de pièces de rechange
Ersatzteilliste
Lista de piezas de repuesto
Lista de peças
Listino ricambi
Onderdelenlijst
Καταλόδος ανταλλακτικῶν
Varaosu luettelo
Reservdelsliste
Reservdelfortegnelse
Reservdelsförteckning

**Pneumatic breakers
Brise-béton pneumatiques
Druckluft-Aufbrechhämmer
Rompedores neumáticos
Martelos pneumáticos
Demolitori pneumatici
Pneumatische sloophammers
Κρουστικές μηχανές
Paineilmakanaet
Trykluftmejselhamre
Pneumatiske spett
Tryckluftspett**

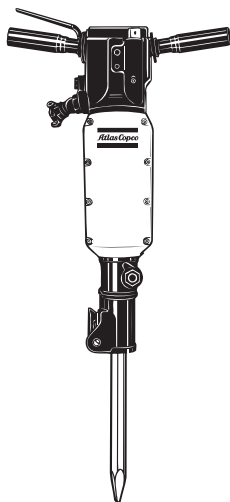

**TEX 32P
TEX 32PS
TEX 33PE
TEX 39P
TEX 39PS
TEX 40PE**

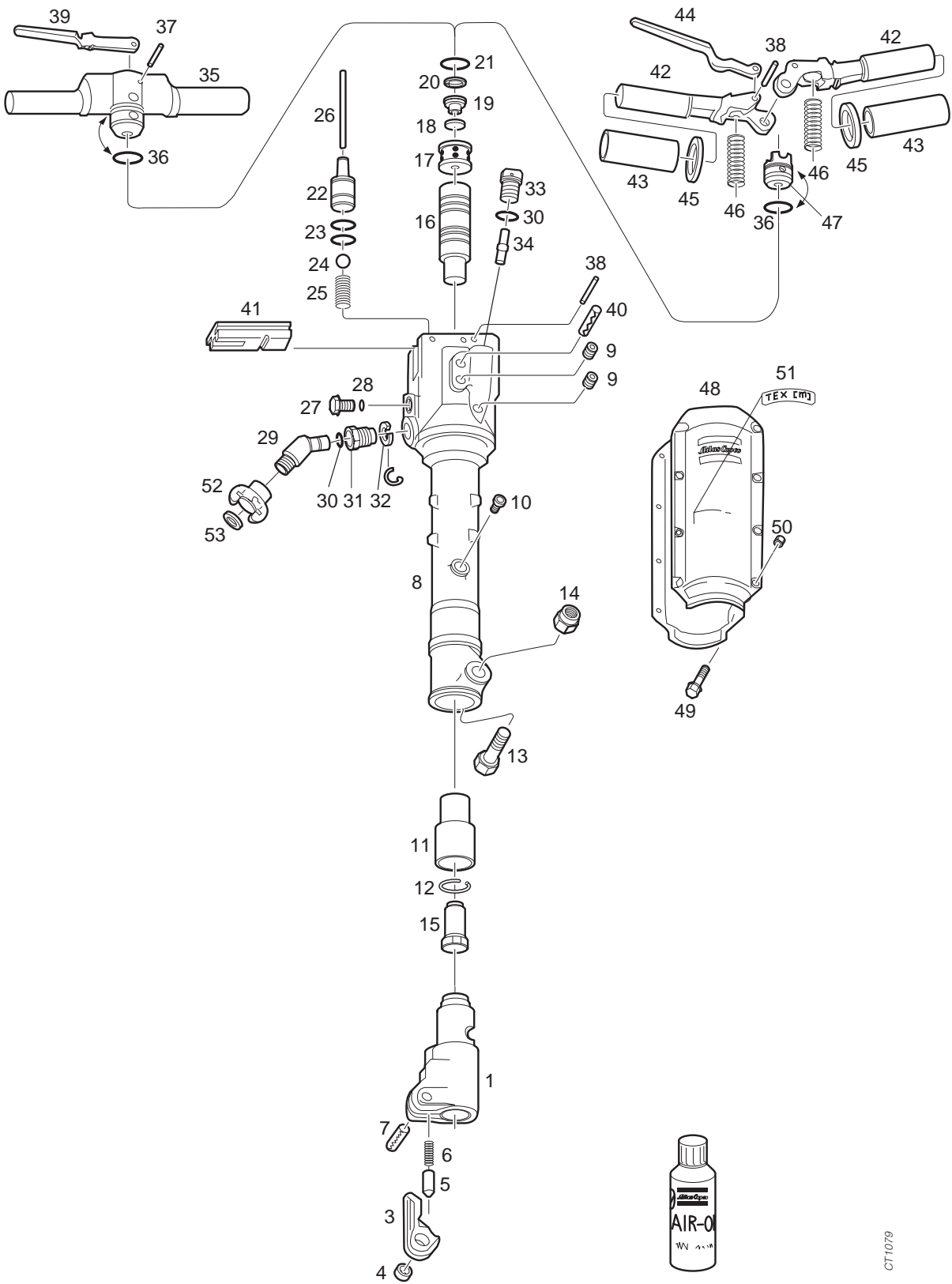

Fig. No. No. de fig. Abb. Nr. Núm. de fig. Fig. No No rif. Fig nr. Αριθ Σχ. Kuva nr. Fig. nr. Fig. nr. Fig. nr.	Ordering No. Référéncie Bestellnummer Núm. pedido Encomenda No No. Cat. Bestel nr. Αριθ. Παραγγελίας Tilaus nro. Bestillingsnummer Bestillingsnummer Best. nummer	Quantity Quantité Anzahl Cantidad Qvantidade Quantità Aantal Ποσότητα Lukumäärä Antal Antall Antal						Description	Dimensions Dimensions Abmessungen Dimensiones Dimensões Dimensioni Afmetingen Διαστάσεις Mitat Dimensioner Dimensioner Dimensioner
32P 32PS 33PE 39P 39PS 40PE									
1	3310 1040 01	1	1	1	1	1	1	Front head, compl.	⊕ 28 x 160 mm
1	3310 1040 00	1	1	1	1	1	1	Front head, compl.	⊕ 32 x 160 mm
	3310 0889 80	1	1	1	1	1	1	Tool retainer, compl.	
3	— *)	1	1	1	1	1	1	– Tool retainer	
4	3310 0892 00	1	1	1	1	1	1	– Bushing	
5	3310 0893 00	1	1	1	1	1	1	Plunger	
6	3310 0894 00	1	1	1	1	1	1	Spring	
7	0108 1691 06	1	1	1	1	1	1	Connex pin	Ø18 x 80 mm
	3310 1116 00	1	1	1	-	-	-	Cylinder, compl.	
	3310 1041 00	-	-	-	1	1	1	Cylinder, compl.	
8	— *)	1	1	1	1	1	1	– Cylinder	
9	0686 6102 00	2	2	2	2	2	2	– Screw plug	ISO 7-R1/4
10	0686 6103 00	1	1	1	1	1	1	– Screw plug	ISO 7-R3/8
11	3310 1118 00	1	1	1	-	-	-	Intermediate part	
11	3310 1049 00	-	-	-	1	1	1	Intermediate part	
12	3310 1053 00	1	1	1	1	1	1	Lock ring	
13	3310 1175 00	1	1	1	1	1	1	Bolt	MJ20 x 100 mm
14	0291 1116 00	1	1	1	1	1	1	Nut	M20 Nyloc
15	3310 1203 00	1	1	1	1	1	1	Anvil	
16	3310 1198 00	1	1	1	-	-	-	Piston	
16	3310 1199 00	-	-	-	1	1	1	Piston	
	3310 1169 90	1	1	1	-	-	-	Valve system, compl.	Red Ø55 mm
	3310 1170 90	-	-	-	1	1	1	Valve system, compl.	Black Ø55 mm
17	— *)	1	1	1	1	1	1	– Valve housing	
18	3310 1173 00	1	1	1	1	1	1	– Main valve	
19	3310 1163 00	1	1	1	1	1	1	– Valve cover	
20	3310 1166 00	1	1	1	1	1	1	– Steel washer	Ø55 mm
21	0663 9253 00	1	1	1	1	1	1	O-ring	Ø43.82 x 5.33 mm
22	3310 1038 00	1	1	1	1	1	1	Valve seat	
23	0663 2105 44	2	2	2	2	2	2	O-ring	Ø31.6 x 1.2 mm
24	3310 0983 00	1	1	1	1	1	1	Ball	Red Ø20 mm
25	3310 1079 00	1	1	1	1	1	1	Spring	
26	3310 1039 00	1	1	1	1	1	1	Valve stem	
27	3310 1042 00	1	1	1	1	1	1	Screw plug	
28	0663 2116 00	1	1	1	1	1	1	O-ring	Ø9.3 x 2.4 mm
29	3310 1043 00	1	1	1	1	1	1	Swivel	G 3/4A
29	3310 1043 01	1	1	1	1	1	1	Swivel	3/4 - 14NPT
30	0663 2126 00	2	2	2	2	2	2	O-ring	Ø22.2 x 3.0 mm
31	3310 1044 00	1	1	1	1	1	1	Swivel nut	
32	3310 1059 00	1	1	1	1	1	1	Lock washer	

Fig. No. No. de fig. Abb. Nr. Núm. de fig. Fig. No No rif. Fig nr. Αριθ Σχ. Kuva nr. Fig. nr. Fig. nr. Fig. nr.	Ordering No. Référence Bestellnummer Núm. pedido Encomenda No No. Cat. Bestel nr. Αριθ. Παραγγελίας Tilaus nro. Bestillingsnummer Bestillingsnummer Best. nummer	Quantity Quantité Anzahl Cantidad Quantidade Quantità Aantal Ποσότητα Lukumäärä Antal Antal Antal	Description	Dimensions Dimensions Abmessungen Dimensiones Dimensões Dimensioni Afmetingen Διαστάσεις Mitat Dimensioner Dimensioner Dimensioner
--	---	--	-------------	---

		32P	32PS	33PE	39P	39PS	40PE		
33	3310 0854 00	1	1	1	1	1	1	Oil plug	G 3/4A
34	3310 1295 00	1	1	1	1	1	1	Dosing feeder	
35	3310 1045 00	1	1	-	1	1	-	Handle	
36	0663 6134 00	1	1	1	1	1	1	O-ring	Ø49.5 x 3.0 mm
37	0102 0320 00	1	1	-	1	1	-	Pin	Ø6 x 25 mm
38	0108 1330 00	1	1	2	1	1	2	Spring pin	Ø6 x 32 mm
39	3310 1046 00	1	1	-	1	1	-	Trigger	
40	0108 1690 67	1	1	1	1	1	1	Connex pin	Ø16 x 100 mm
41	3310 1047 00	1	1	1	1	1	1	Cover	
	3310 1105 80	-	-	2	-	-	2	Handle, compl.	
42	— *)	-	-	2	-	-	2	– Handle	
43	3310 1132 00	-	-	2	-	-	2	– Sleeve	
44	3310 1082 00	-	-	1	-	-	1	Trigger	
45	3310 1085 00	-	-	2	-	-	2	Rubber washer	
46	3310 1107 00	-	-	2	-	-	2	Spring	
47	3310 1160 00	-	-	1	-	-	1	Seal plug	
	3310 1229 80	-	1	1	-	1	1	Silencer, compl.	
48	— *)	-	1	1	-	1	1	– Silencer	
49	0147 1976 06	-	8	8	-	8	8	– Flange screw	M6 x 62 mm
50	9232 0207 50	-	8	8	-	8	8	– Flange nut	M6 Triloc
51	3310 1120 00	1	-	-	-	-	-	Plate TEX 32P	
51	3310 1120 01	-	1	-	-	-	-	Plate TEX 32PS	
51	3310 1120 02	-	-	1	-	-	-	Plate TEX 33PE	
51	3310 1033 00	-	-	-	1	-	-	Plate TEX 39P	
51	3310 1033 01	-	-	-	-	1	-	Plate TEX 39PS	
51	3310 1033 02	-	-	-	-	-	1	Plate TEX 40PE	
52	9000 0306 00	1	1	1	1	1	1	Claw coupling, compl.	G 3/4"
53	9000 0000 00	1	1	1	1	1	1	– Packing	
52	9001 0005 06	1	1	1	1	1	1	Claw coupling, compl.	3/4 - 14NPT
53	9001 0005 15	1	1	1	1	1	1	– Packing	

*) Not delivered separately/ Non disponible en pièces de rechange/ Nicht separat lieferbar/ No se entrega como repuesto/ Non fornibile separatamente/ Não é vendid/ Niet afzonderlijk leverbaar/ Δεν παρέχεται ξεχωριστά/ Ei toimiteta erikseen/ Leveres ikke separat/ Leveres ikke som reservdel/ Levereras ej som reservdel

Fig. No. No. de fig. Abb. Nr. Núm. de fig. Fig. No No rif. Fig nr. Αριθ Σχ. Kuva nr. Fig. nr. Fig. nr. Fig. nr.	Ordering No. Référéce Bestellnummer Núm. pedido Encomenda No No. Cat. Bestel nr. Αριθ. Παραγγελίας Tilaus nro. Bestillingsnummer Bestillingsnummer Best. nummer	Description	Dimensions Dimensions Abmessungen Dimensiones Dimensões Dimensioni Afmetingen Διαστάσεις Mitat Dimensioner Dimensioner Dimensioner
--	--	-------------	---

Synthetic oil AIR-OIL/ Huile synthétique AIR-OIL/ Synthetisches Öl AIR-OIL/ Aceite sintético AIR-OIL/ Sintético óleo AIR-OIL/ Olio sintetico AIR-OIL/ Synthetische olie AIR-OIL/ Συνθετικό λάδι AIR-OIL/ Syn-teettinen öljy AIR-OIL/ Syntetisk olie AIR-OIL/ Syntetisk olje AIR-OIL/ Syntetisk olja AIR-OIL

8099 0202 40	Air oil bottle	0.2 l
8099 0202 36	Air oil bottle	1 l
8099 0202 02	Air oil container	5 l
8099 0202 20	Air oil container	25 l
8099 0202 28	Air oil barrel	200 l

Use only authorized parts. Any damage or malfunction caused by the use of unauthorized parts is not covered by Warranty or Product Liability.

N'utiliser que des pièces approuvées. Tout endommagement ou fonctionnement défectueux résultant de l'utilisation de pièces non approuvées n'est pas couvert par Garantie et responsabilité du produit.

Nur Zugelassene Teile verwenden. Schäden oder Funktionsstörungen, die auf die Verwendung nicht zugelassener Teile zurückzuführen sind, fallen nicht unter die Garantie- oder Produkthaftungsbestimmungen.

Sólo se pueden usar piezas autorizadas. Cualquier daño o funcionamiento defectuoso causado por el uso de piezas no autorizadas no se cubren por la Garantía o la Responsabilidad del Producto.

Use apenas peças autorizadas. Qualquer avaria ou mau funcionamento motivado pelo uso de peças não é coberto por garantia ou responsabilidade de riscos causados pelo produto.

Usare solamente parti autorizzate. I danni o disturbi del funzionamento causati dall'uso di parti non autorizzate, non sono coperti dalla Garanzia né dall'Assicurazione del prodotto.

Gebruik uitsluitend geautoriseerdeonderdelen. Schade of gebreken veroorzaakt door het gebruik van niet-geautoriseerde onderdelen vallen niet onder de garantie of de produkt-aansprakelijkheid.

Χρησιμοποιείτε μόνο εγκεκριμένα εξαρτήματα. Τυχόν καταστροφή ή βλάβη η οποία προκαλείται από τη χρήση μη εγκεκριμένων εξαρτημάτων δεν καλύπτεται από την Εγγύηση ή την Ευθύνη Προϊόντος.

Käytä vain hyväksytyjä varaosia. Takuu ja tuotevastuu eivät korvaa hyväksymättömien varaosien käytöstä aiheutuvia vaurioita tai toimintahäiriöitä.

Brug kun autoriserede dele. Enhver skade eller fejlfunktion, der skyldes brugen af ikke-autoriserede dele, er ikke dækket af garantien eller produktansvarsforsikringen.

Bruk bare godkjente deler. Enhver skade eller funksjonsfeil som skyldes bruk av ikke godkjente deler dekkes ikke av garanti eller produktansvar.

Använd endast godkända reservdelar. Skada eller funktionsfel som beror på användning av ej godkända reservdelar täcks inte av garantiätaganden eller produktansvar.

Any unauthorized use or copying of the contents or any part thereof is prohibited. This applies in particular to trademarks, model denominations, part numbers and drawings.

Toute utilisation ou reproduction non autorisée du contenu, ou d'une partie du contenu, est illicite. Cela s'applique particulièrement aux marques déposées, aux désignations de modèles, aux numéros de pièces et aux plans.

Unbefugter Gebrauch oder das Kopieren des Inhalts, auch auszugsweise, ist verboten. Dies gilt besonders für Warenzeichen, Modellbezeichnungen, Teilnummern und Zeichnungen.

Está prohibido cualquier uso o copia no autorizada del contenido o de cualquier parte de éste. Esto se aplica en especial a marcas registradas, denominaciones de modelos, números de piezas y dibujos.

Qualquer utilização não autorizada ou cópia de qualquer peça é expressamente proibida. Isto aplica-se em particular às marcas registradas, denominação dos modelos, referência de peças e desenhos.

E' vitata qualsiasi forma d'uso o copiatura non autorizzata del contenuto, anche parziale, con particolare riguardo ai marchi di fabbrica, alle denominazioni dei modelli, ai numeri delle parti ed ai disegni.

Niet-geautoriseerd gebruik of kopiëren van de inhoud of een deel daarvan is niet toegestaan. Dat geldt in het bijzonder voor handelsmerken, model-benamingen, onderdeel nummers en tekeningen.

Τυχόν μη εξουσιοδοτημένη χρήση ή αντιγραφή των περιεχομένων οποιουδήποτε μέρους του παρόντος απαγορεύεται. Αυτό ισχύει ιδιαίτερα στα σήματα κατατεθέντα, τις ονομασίες μοντέλων, τους αριθμούς ανταλλακτικών και τα σχεδιαγράμματα.

Sisällön tai sen osan luvaton käyttö tai kopiointi on kielletty. Tämä koskee erityisesti tavaramerkkejä, mallien nimiä, osanumeroita ja piirustuksia.

Enhver ikke-autoriseret brug eller kopiering af indholdet eller nogen del deraf er forbudt. Dette gælder især varemærker, modelbetegnelser, reservedelsnumre og tegninger.

Enhver ikke godkjent bruk eller kopiering av innholdet eller noen del av det er forbudt. Dette gjelder i særlig grad varemærker, modellbetegnelser, delnummer og tegninger.

Ej i förväg godkänd användning eller kopiering av innehållet eller del av detta är förbjuden. Detta gäller speciellt varumärken, modellbeteckningar, reservedelsnummer och ritningar.



Any unauthorized use or copying of the contents or any part thereof is prohibited.
This applies in particular to trademarks, model denominations, part numbers and drawings.

© 2006 Atlas Copco Construction Tools AB, Stockholm, Sweden | No. 9853 5918 90e | 2006-10-20